

Reverse Brake Assembly

CONTINUOUSLY VARIABLE TRANSMISSION

36.Reverse Brake Assembly

A: REMOVAL

NOTE:

For removal of reverse brake assembly, refer to “Intermediate Case”. <Ref. to CVT(TR690)-165, REMOVAL, Intermediate Case.>

B: INSTALLATION

NOTE:

For installation of reverse brake assembly, refer to “Intermediate Case”. <Ref. to CVT(TR690)-166, INSTALLATION, Intermediate Case.>

C: DISASSEMBLY

- 1) Remove the snap ring.
- 2) Remove the retaining plate, drive plate, driven plate and dish plate.

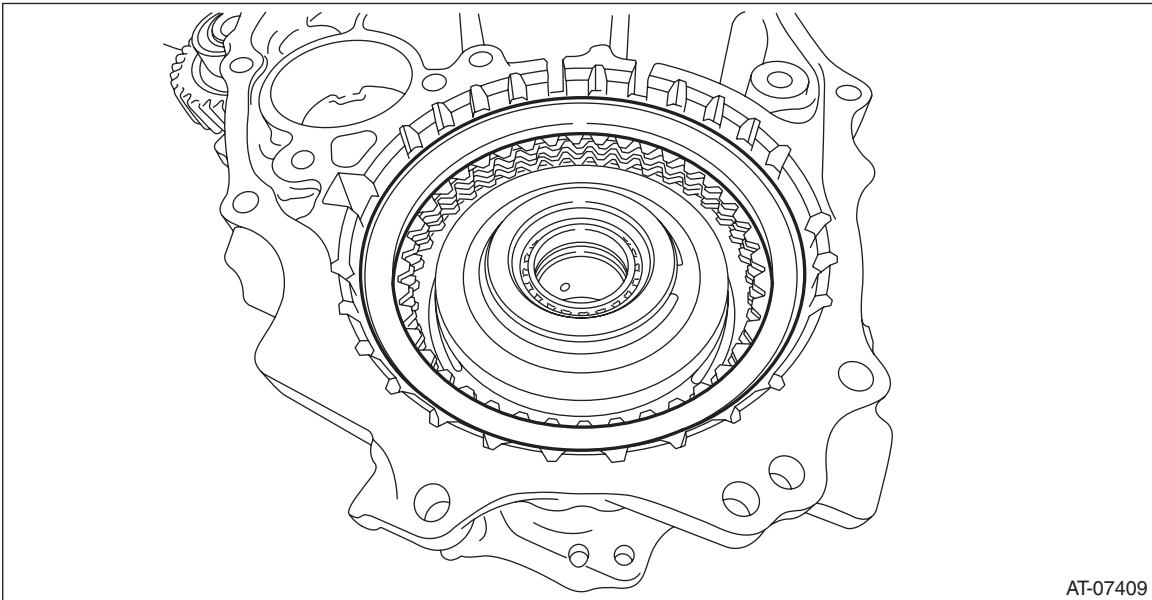

Reverse Brake Assembly

CONTINUOUSLY VARIABLE TRANSMISSION

3) Set the ST1, ST2 and ST3 to intermediate case.

ST1 18762AA001 COMPRESSOR SPECIAL TOOL

ST2 18763AA000 COMPRESSOR SHAFT

ST3 18765AA000 COMPRESSOR SUPPORT

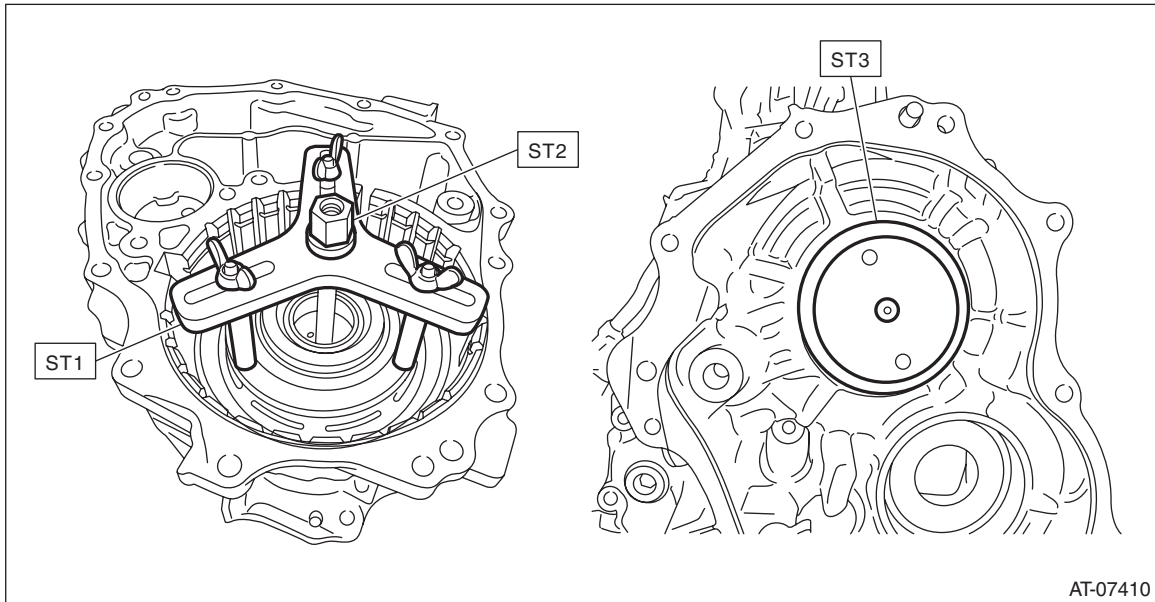

4) Compress the return spring using the set ST to remove the snap ring.

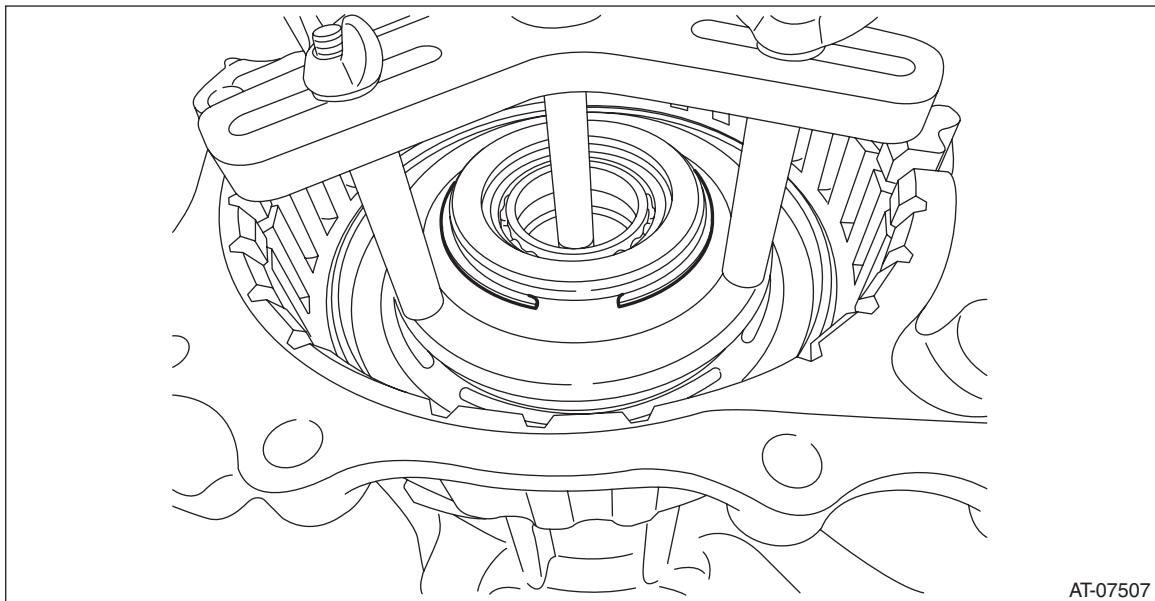

Reverse Brake Assembly

CONTINUOUSLY VARIABLE TRANSMISSION

5) Using the ST, remove the snap ring and spring retainer.

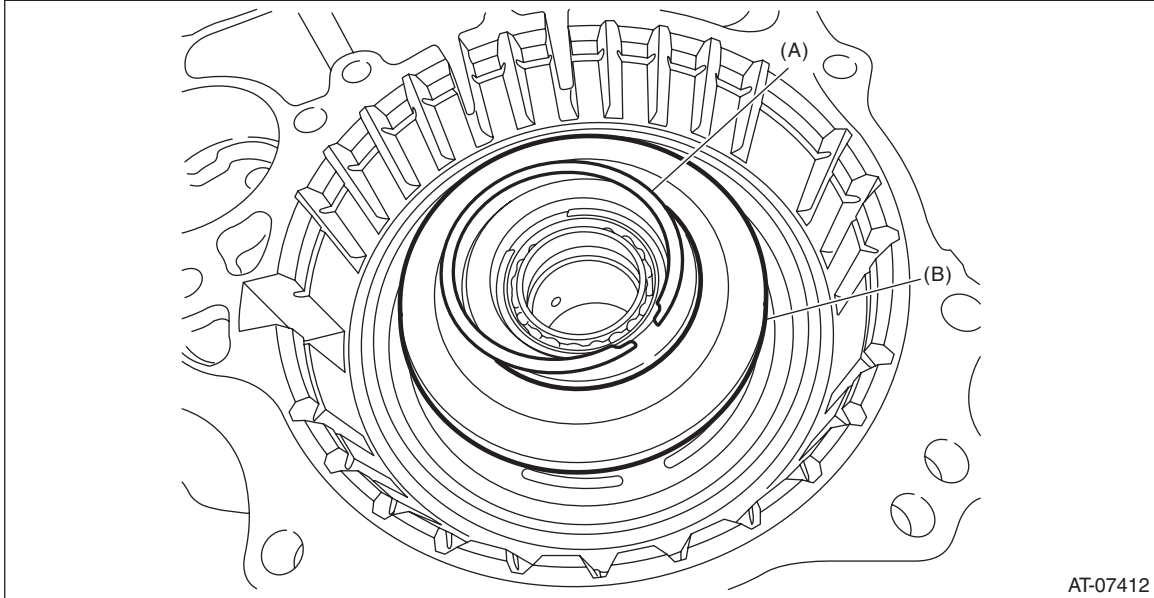

- (A) Snap ring
- (B) Spring retainer

6) Remove the return spring.

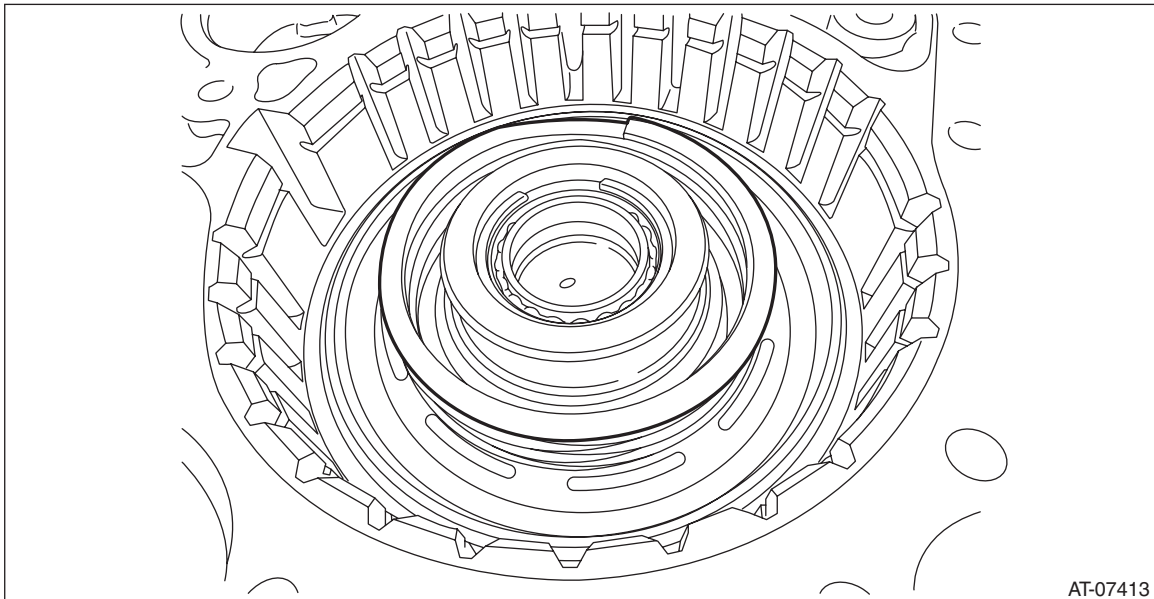

Reverse Brake Assembly

CONTINUOUSLY VARIABLE TRANSMISSION

- 7) Remove the reverse brake piston by blowing compressed air intermittently from intermediate case hole.

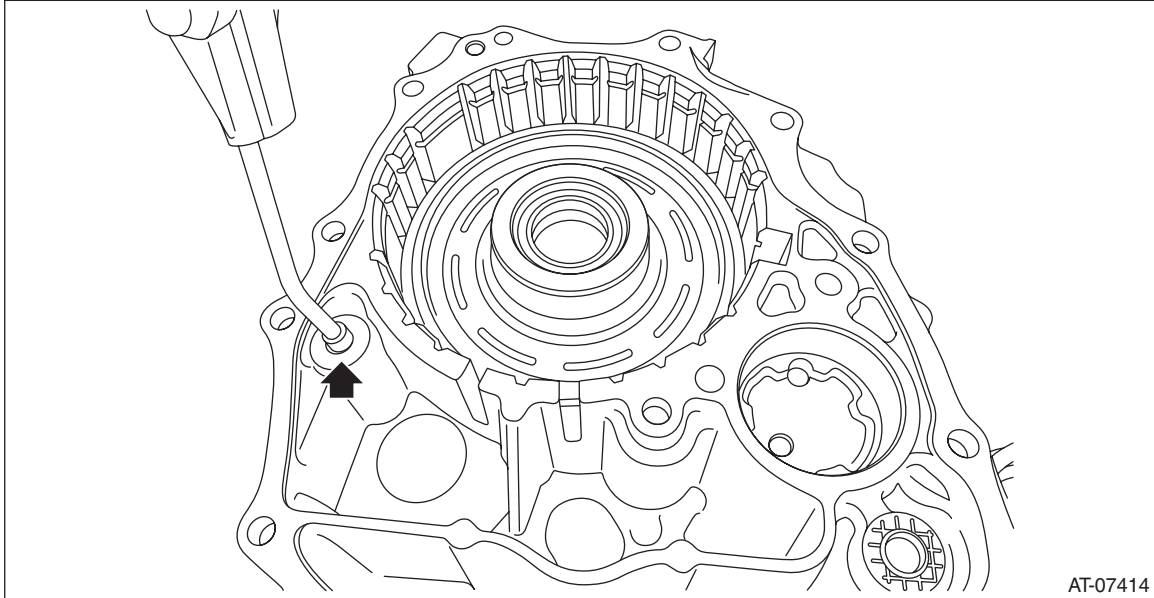

D: ASSEMBLY

- 1) Apply CVTF to the seal of reverse brake piston and install it to intermediate case.

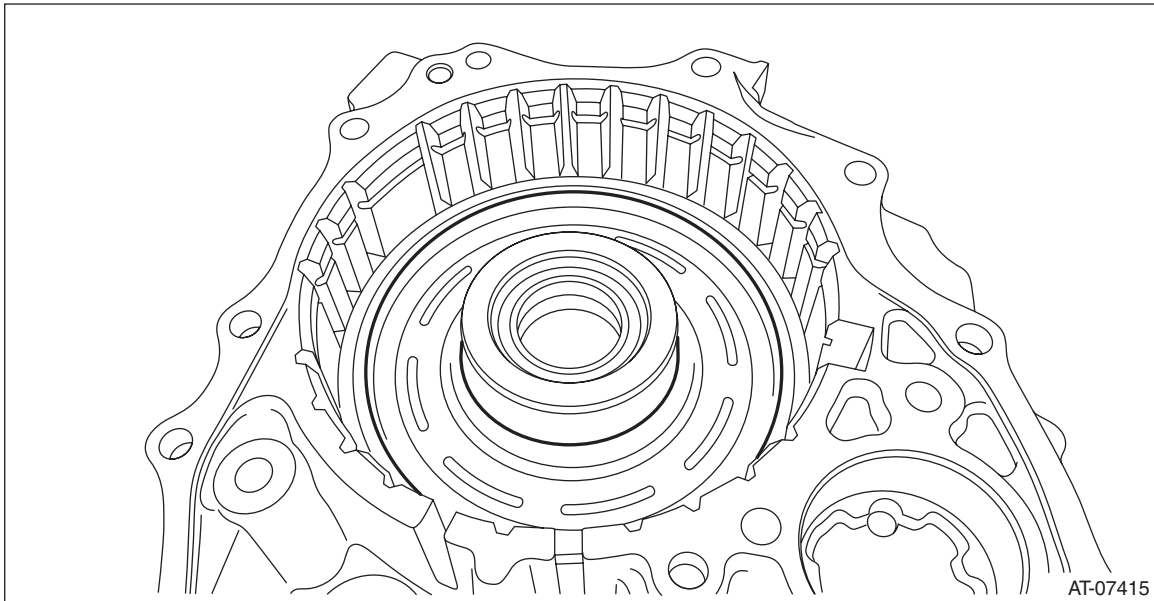

Reverse Brake Assembly

CONTINUOUSLY VARIABLE TRANSMISSION

2) Install the return spring.

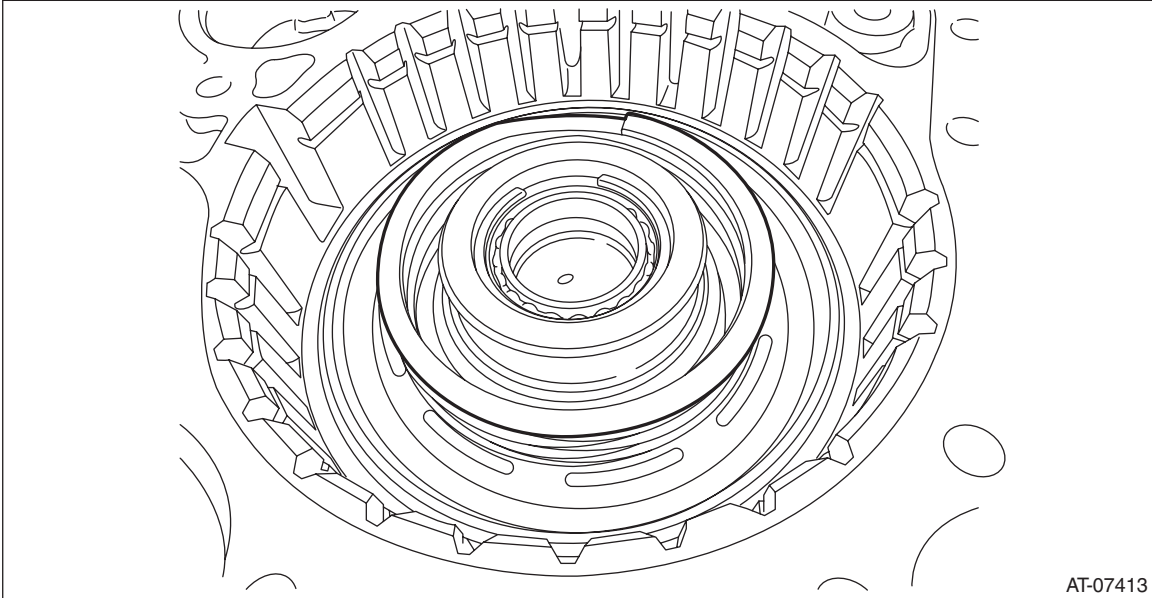

3) Set the spring retainer and snap ring.

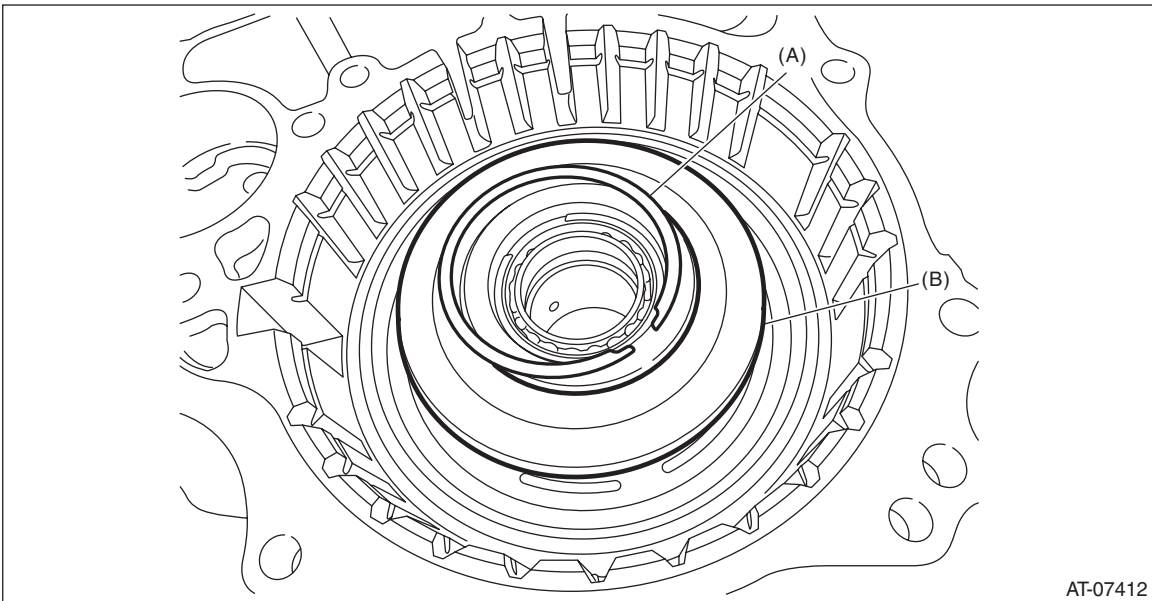

- (A) Snap ring
- (B) Spring retainer

Reverse Brake Assembly

CONTINUOUSLY VARIABLE TRANSMISSION

4) Set the ST1, ST2 and ST3 to intermediate case.

ST1 18762AA001 COMPRESSOR SPECIAL TOOL

ST2 18763AA000 COMPRESSOR SHAFT

ST3 18765AA000 COMPRESSOR SUPPORT

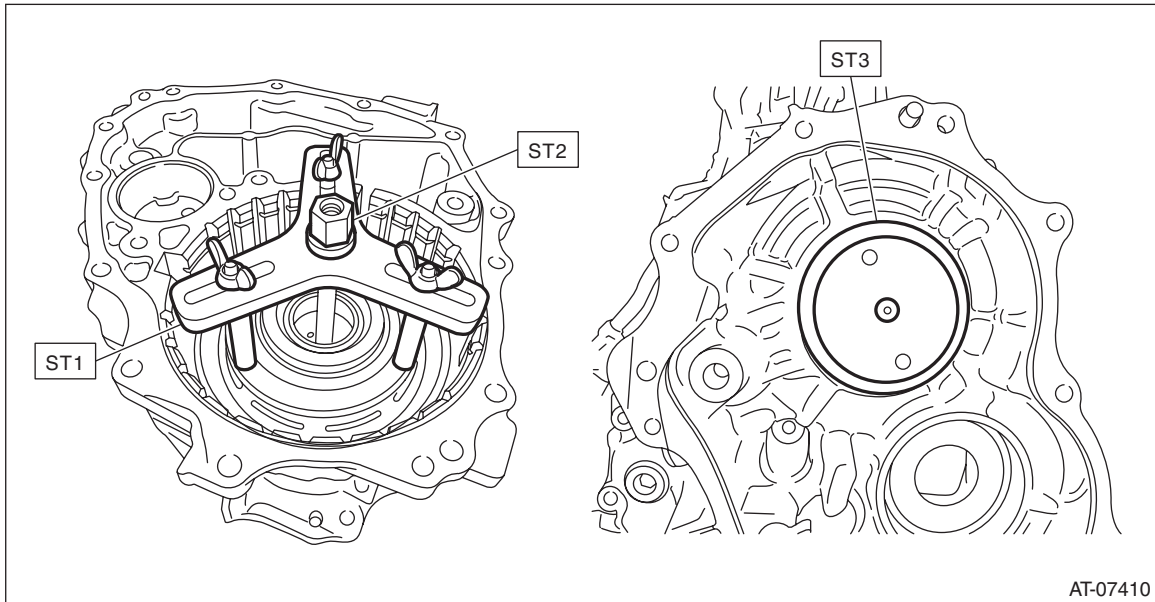

5) Compress the return spring using the ST attached, and install the snap ring.

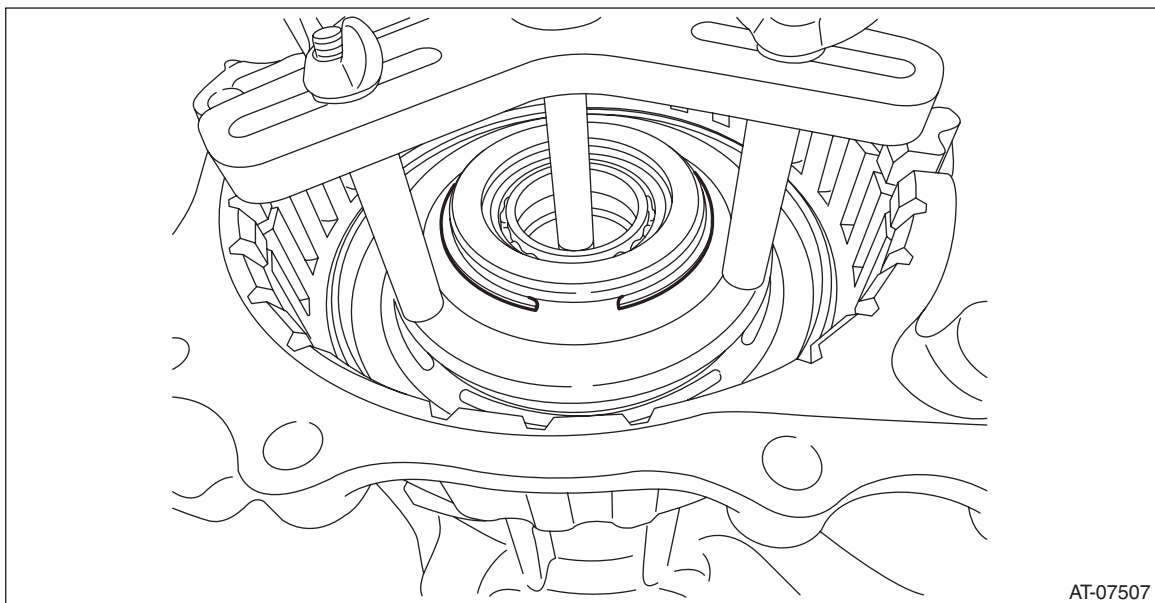

Reverse Brake Assembly

CONTINUOUSLY VARIABLE TRANSMISSION

6) Check the operation of reverse brake piston by blowing compressed air intermittently from intermediate case hole.

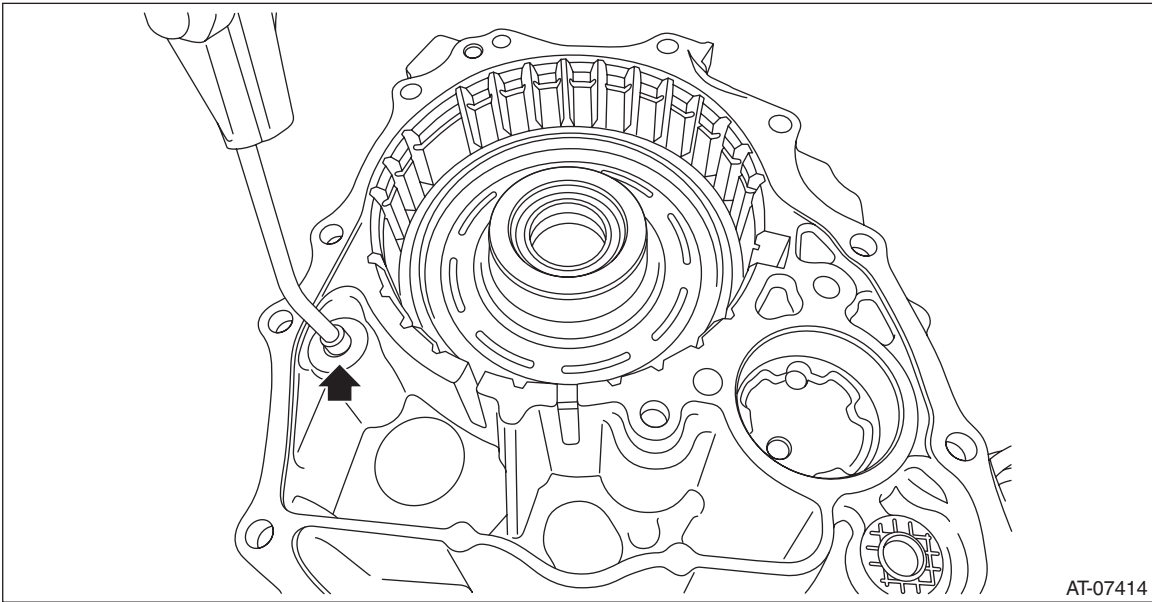

7) Place the dish plate, driven plate, drive plate and retaining plate neatly in this order on surface table.

8) Set the dial gauge to retaining plate, and read its scale.

NOTE:

The value, which is read in the gauge at this time, is zero point.

9) Scale and record the weight "Z" of a flat board which will be put on retaining plate.

NOTE:

- Use a stiff board which does not bend against load as a flat board to be put on retaining plate.
- Use a flat board weighing less than 84 N (8.6 kgf, 18.9 lb).

10) Put the flat board on retaining plate.

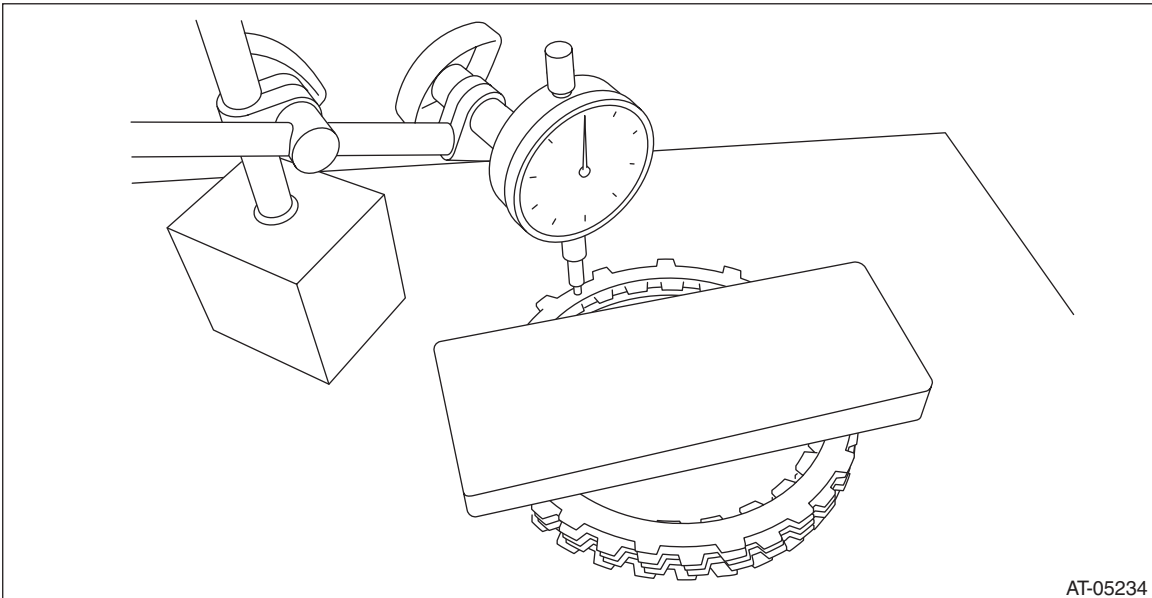

11) Using the following formula, read the push/pull gauge, and calculate "N".

$$N = 84 \text{ N (8.6 kgf, 18.9 lb)} - Z$$

84 N (8.6 kgf, 18.9 lb) : Load applied to clutch plate

Z: Flat board weight

Reverse Brake Assembly

CONTINUOUSLY VARIABLE TRANSMISSION

12) Press the center of retaining plate by applying a force of “N” or more using push/pull gauge, and then measure and record the compression amount “A”.

NOTE:

Measure at four points with a 90° interval and calculate the average.

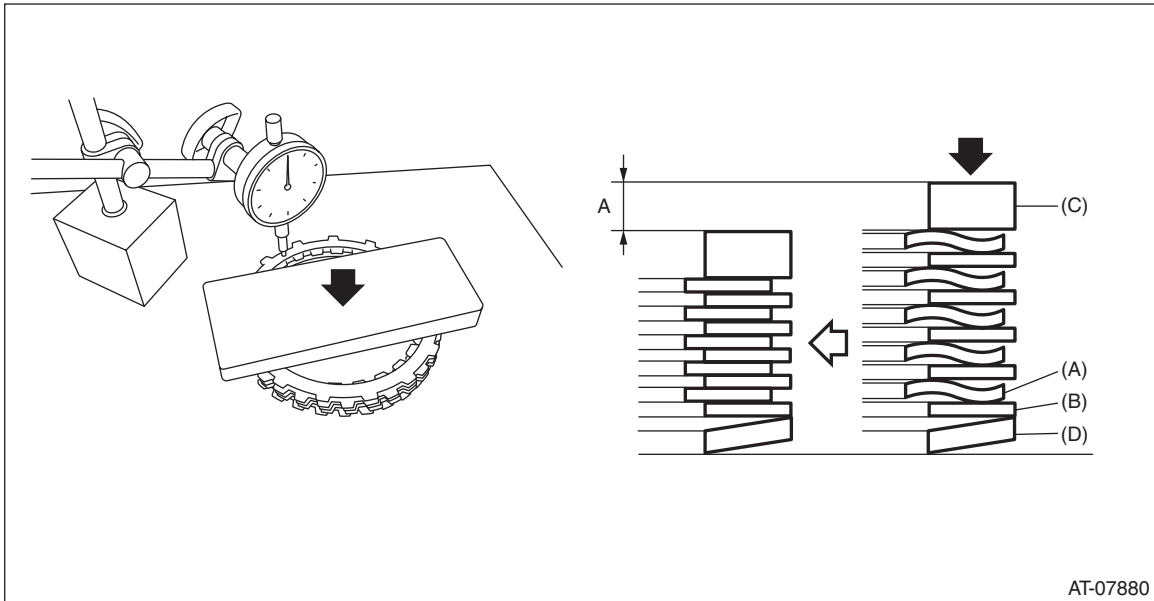

- (A) Drive plate
- (B) Driven plate
- (C) Retaining plate
- (D) Dish plate

13) Install the dish plate, drive plate, driven plate, retaining plate and snap ring to intermediate case.

NOTE:

Install the dish plate in the correct direction.

14) Measure and record the clearance “B” between the retaining plate and snap ring.

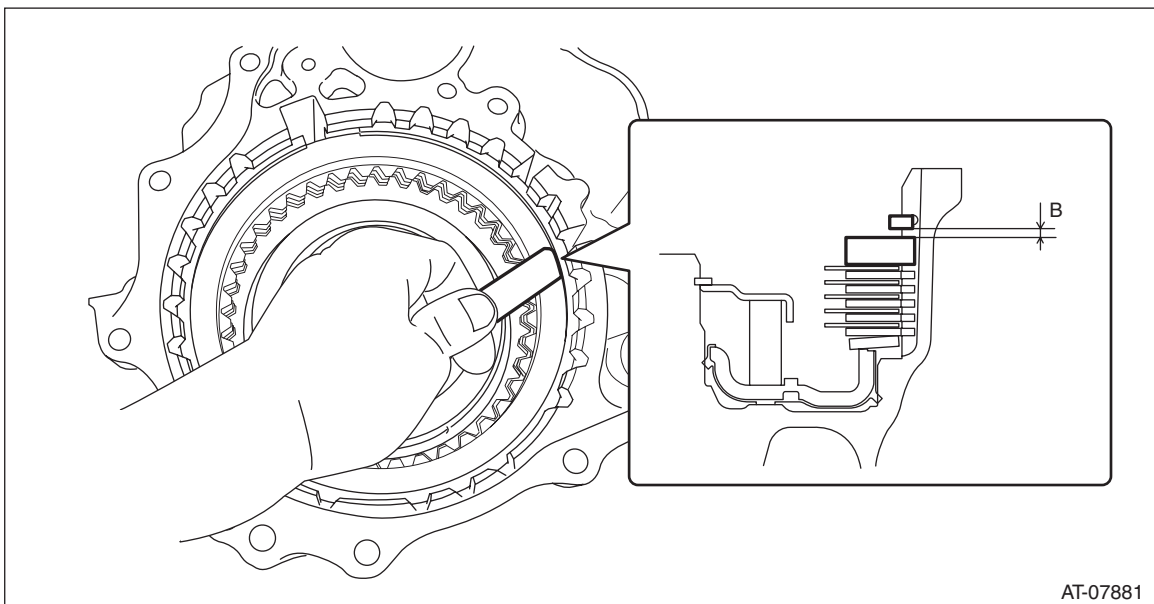

Reverse Brake Assembly

CONTINUOUSLY VARIABLE TRANSMISSION

15) Piston stroke calculation

Calculate with A and B dimensions recorded before. If it exceeds the limit, replace with a new drive plate and adjust within the initial standard value.

$$S \text{ mm (in)} = A + B$$

S: Piston stroke

A: Compression amount of drive plate and dish plate

B: Clearance between retaining plate and snap ring

Initial standard:

2.88 — 3.18 mm (0.113 — 0.125 in)

Limit thickness:

3.38 mm (0.133 in)

Retaining plate	
Part No.	Thickness mm (in)
31567AB680	5.6 (0.220)
31567AB690	5.8 (0.228)
31567AB700	6.0 (0.236)
31579AB710	6.2 (0.244)

E: INSPECTION

- Inspect the drive plate facing for wear and damage.
- Check the driven plate for discoloration (burnt color).
- Check for worn snap ring, fatigue or damaged return spring or deformed spring retainer.
- Make sure the clearance between retaining plate and snap ring of reverse brake is within the limit. If it exceeds the limit, replace with a new drive plate and select and adjust the retaining plate within the initial standard value. <Ref. to CVT(TR690)-175, ASSEMBLY, Reverse Brake Assembly.>